

Checkpoint Short Arrow®

Checkpoint® is the first ever wheel nut indicator with wheel overheating indication.

The short arrow version is designed for low loaders.

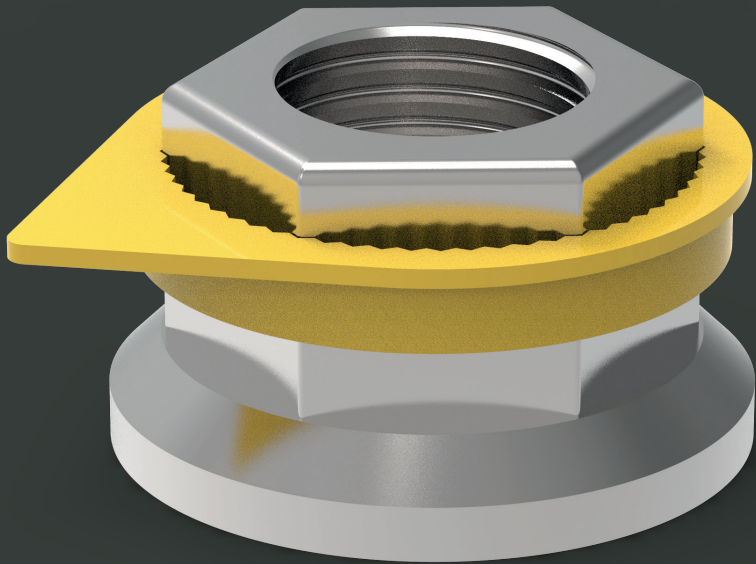

AVAILABLE

Colour	Size (mm)
Fluoro Yellow	17
	18
Red	19
	20
Solid Yellow	21
	22
Green	23
	24
Orange	25
	26
Blue	27
	28
Olive Grey	29
	30
Black	31
	32
Silver Grey	33
	34
White	35
	36
	37
	38
	39
	40
	41
	42
	43
	44
	45
	46
	47
	48
	49
	50

Checkpoint Short Arrow®

Product: Checkpoint Short Arrow®
Yellow 30mm

Product Code: CPSAY30

Function: The Checkpoint Short Arrow® visually indicates wheel nut movement. It will also melt to highlight any overheating issues with the wheel. The short arrow version is designed for wheels with 225 pitch circle diameters (PCDs).

Material: We use high-grade virgin polymer to ensure product quality and reliability as an overheating indicator.

Melt temperature:

125°C/257°F (standard version).

165°C/329°F (HT version).

Application: Mainly for commercial vehicles with 17.5 or 19 inch wheels such as low loaders, double deckers and trailers.

Main benefits: Improves the safety of nut fittings.
Enables quick and easy visual checks and monitoring.
Reduces maintenance costs by saving time and money.

Sizes: All sizes are measured across the flat (a/f) of the nut (in mm). Available in sizes as shown on the front page.

Colour: Other colours are available subject to quantity.

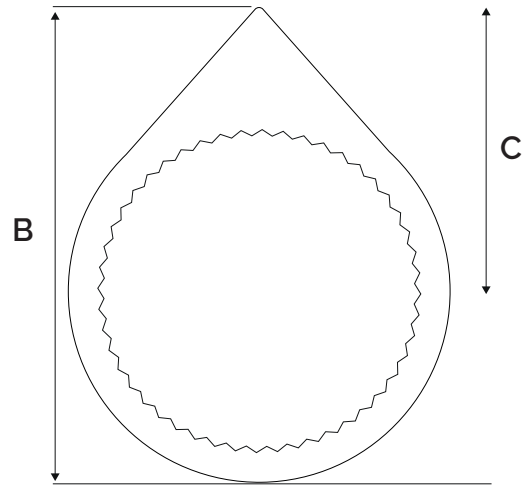

Specifications

A = 7 mm

B = 55 mm

C = 34 mm

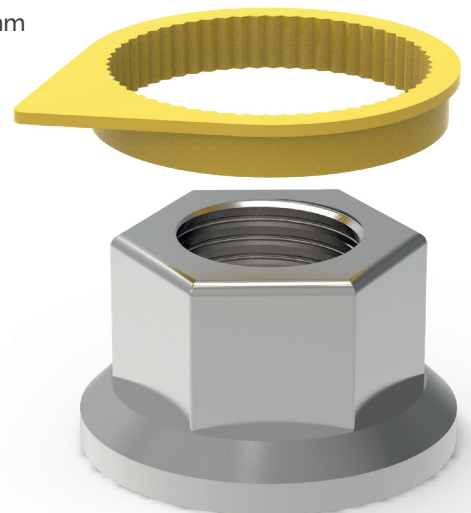

SPECIFICATIONS ARE VALID FOR ALL COLOURS IN THIS SIZE

**GLOBAL LEADERS
IN WHEEL SAFETY**

Tel: +44 (0)1524 271 200
info@checkpoint-safety.com
www.checkpoint-safety.com

Checkpoint®
THE ORIGINAL AND THE BEST