

Mammut 220 Ton Jack

MODEL 91008

ESCO

PRO SERIES

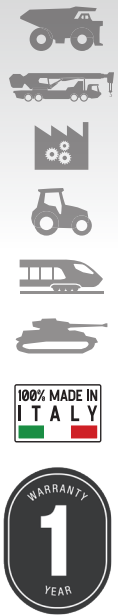

MAMMUT

FEATURES & BENEFITS

- Lightweight, compact and easy to handle/use design.
- Folding handle for easier transport and storage.
- Large wide pneumatic tires designed for use in extreme conditions.
- Special hook for transport and easy transport of jack.
- Standard remote control for lifting and lowering jack from a safe distance away from the load.
- Accessories available - See back of flyer for details.
- 100% manufactured in Italy
- One Year Warranty

MINING AND SPECIAL APPLICATIONS JACKS

MAMMUT jacks are a safe and efficient lifting solution, suitable for vehicle maintenance in the mining, industrial, rail, construction, port and military industries.

Air-hydraulic operated, all models are equipped with double descent valve for a better control and a safer holding under load, with automatic piston return.



SPECIFICATIONS

Model	91008
Style	M200-65
Capacity	220 ton 200 t
Net Weight	848 lb 385 kg
Working Air Pressure	145-174 psi 10-12 bar
Air Consumption	600 nl/min
Max. Height	39.3 in 1000 mm
Min Height	25.5 in 650 mm
Number of Pistons	1
Stroke	13.7 in 350 mm
Application	Mine and oil field, Construction site, Industrial assembly, Agricultural, Railway applications, Military
Warranty	One Year Warranty
UPC	816904025502

Specifications & Accessories

MODEL 91008

The **MAMMUT RANGE OF JACKS** offers service professionals a solution that is safe and easy to use, for all those operations to lift earthmoving, construction, quarry, and mining machinery, where maintenance requires professional skills and expertise. All models are air/hydraulic operated and equipped with a dual descent valve for greater control when bearing weight and automatic piston return; they can also be fitted with a manual emergency pump (on request).

Specifications

MAMMUT

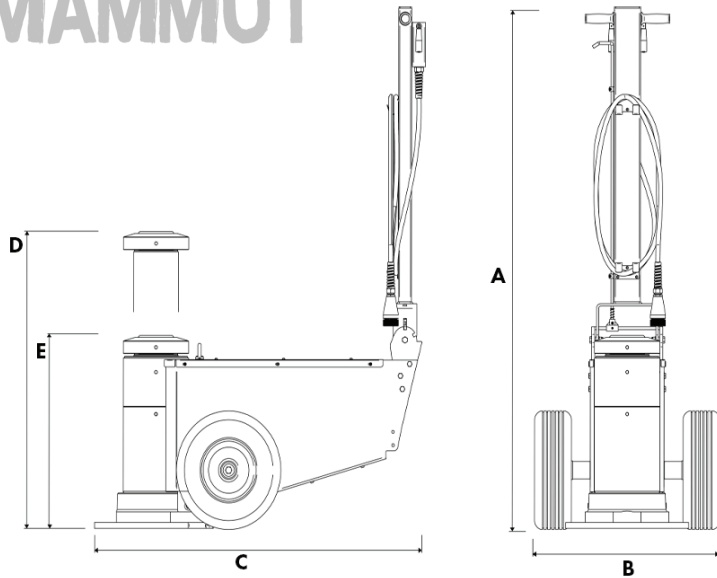

A	69.2 in 1757 mm
B	27.8 in 708 mm
C	49.3 in 1253 mm
D	39.3 in 1000 mm
E	25.5 in 650 mm

Accessories

Model	Description	Specs
91035	Extension Holder R	NA
91034	Extension Holder L	NA
91049	Tilting Plate	A: 3 in B: 2.125 in A: 77mm B: 55mm
91029	Extension	A: 7.875 in B: 2.125 in C: 2.125 in A: 200mm B: 55mm C: 55mm
91030	Extension	A: 9.875 in B: 2.125 in C: 2.125 in A: 250mm B: 55mm C: 55mm
91031	Extension	A: 11.875 in B: 2.125 in C: 2.125 in A: 300mm B: 55mm C: 55mm
91009	Safety Lock Holder	Safety Lock Holder (4) Safety Block (H) 4 - (W) 9.875 in Safety Block (H) 2 - (W) 9.875 in

NOTE: ESCO reserves the right to change, alter, or modify product(s) without notice. This includes but is not limited to product: color, design, parts, accessories, etc.

sales@esco.net **WWW.ESCO.NET** 1.800.352.9852



COPYRIGHT 2022 • 15270 Flight Path Drive • Brooksville, FL 34604

